

LEWA ecoflow® The innovative metering pumps

The universal metering pump series
in proven modular system

- **Safe**
- **Economical**
- **Precise**

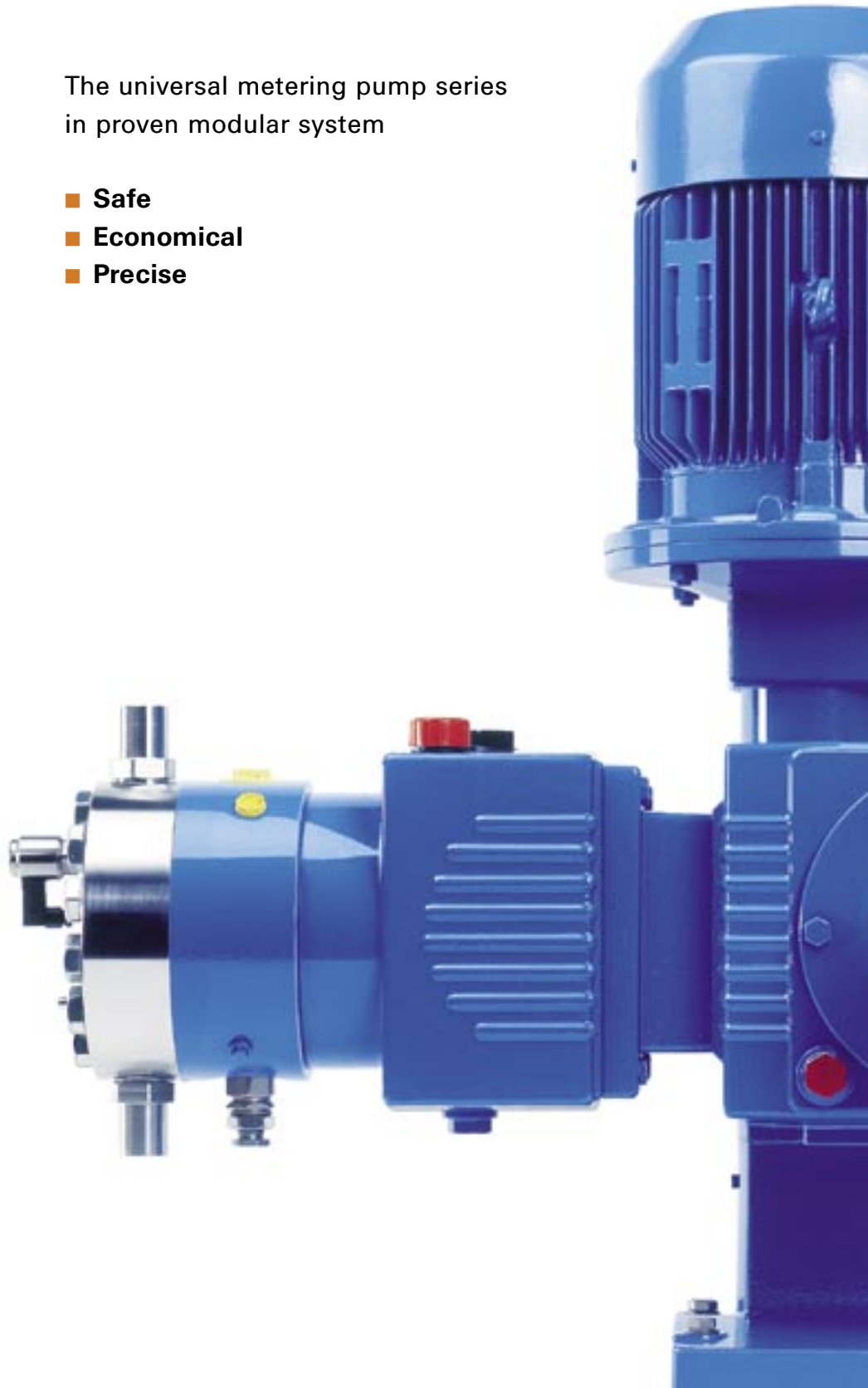

LEWA ecoflow: safe and economical



*Four individual drive elements:
they cover the performance range
from 0,1 l/h to 10 m³/h per pump head*



*Absolutely safe to operate and
economical: sturdy drive elements,
pump heads, drives and accessories
assure a long pump service life*



*Process monitoring and
guiding: simple integration
in the complete plant*

With a completely new developed metering pump programme LEWA set a new standard for highest operating safety and reliability.

LEWA ecoflow is based on:

- 50 years of experience and the widest application range available on the market
- Intensive research work specially for the diaphragm pump technology
- Systematic product development and ambitious goals for customer benefit, quality and economy as well as comprehensive testing in excess of 500.00 hours
- State of the art production technology and handling organisation

LEWA ecoflow offers:

- New drive elements in four frame sizes for simplex and multiplex pumps with manual, electric or pneumatic stroke adjustment
- New PTFE diaphragm pump heads up to 400 bar
- Metal diaphragm pump heads up to 1200 bar
- Plunger pump heads up to 500 bar
- Simple spare parts stocking by a high share of re-usable and identical parts in a modular system
- Different drives
- Solutions for monitoring, control and automation
- Wide range of pipe line connections



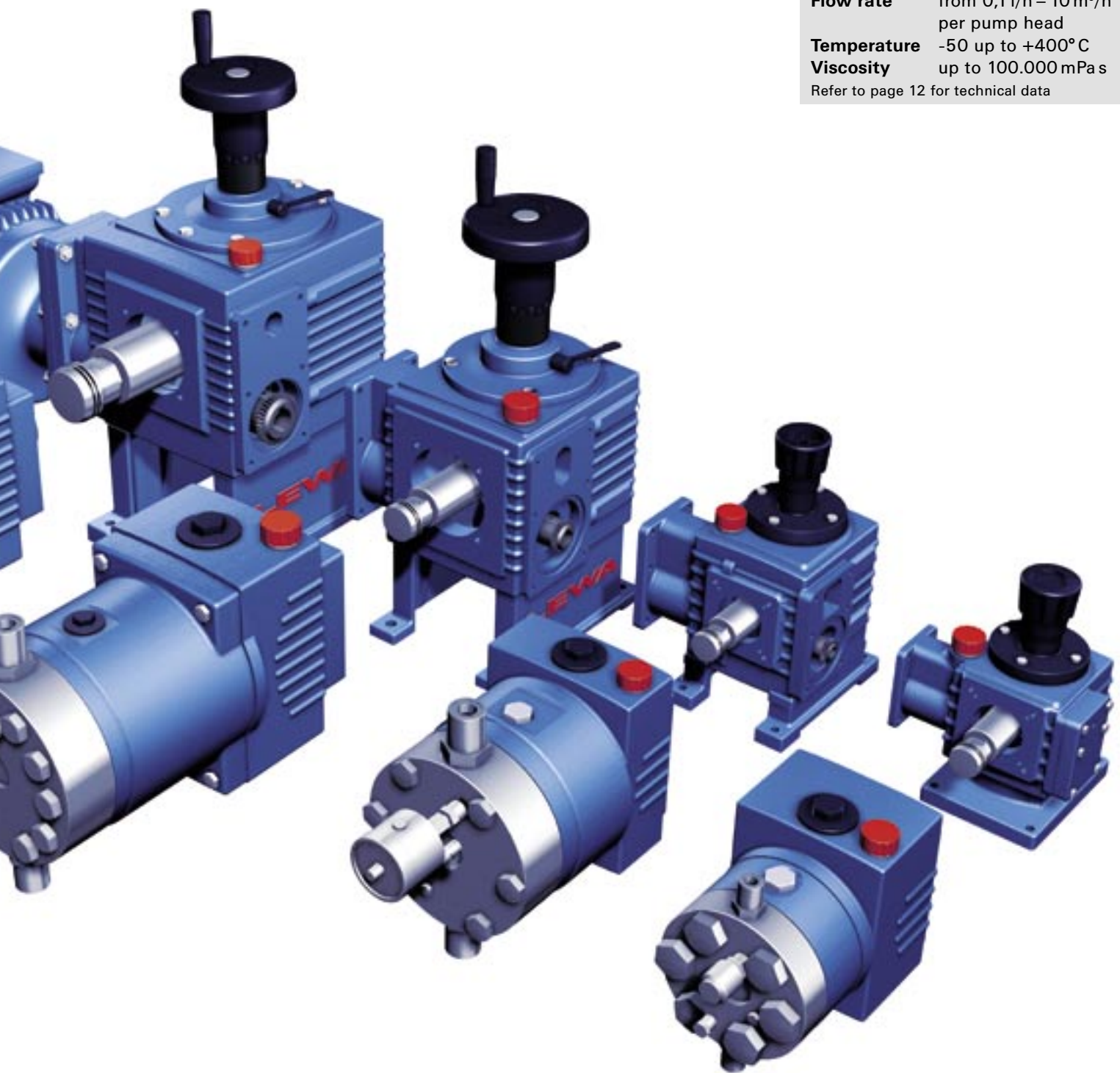

Performance table

Pressure	up to 1200 bar
Flow rate	from 0,1 l/h – 10 m ³ /h per pump head
Temperature	-50 up to +400° C
Viscosity	up to 100.000 mPa s

Refer to page 12 for technical data

Variable eccentric drive elements type LD: sturdy and reliable

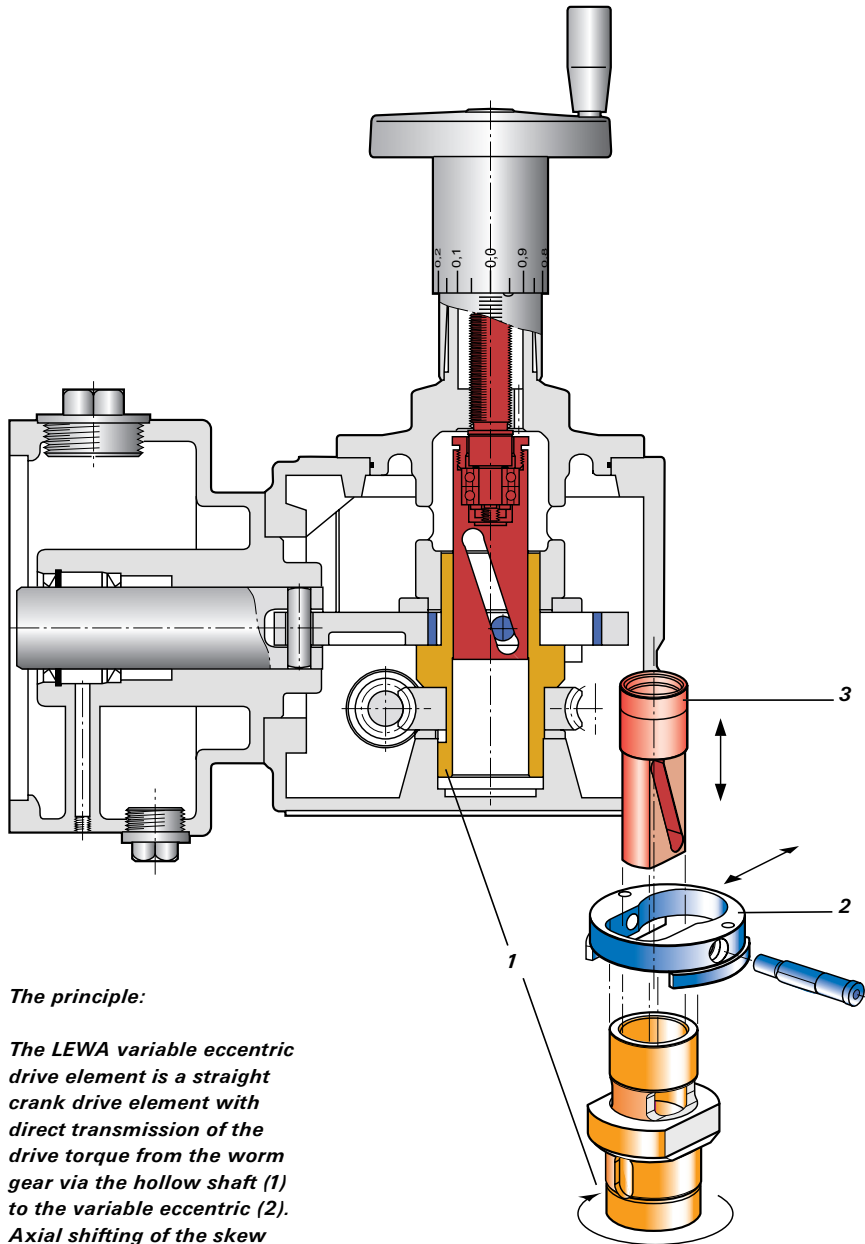

The principle:

The LEWA variable eccentric drive element is a straight crank drive element with direct transmission of the drive torque from the worm gear via the hollow shaft (1) to the variable eccentric (2). Axial shifting of the skew slotted sliding shaft (3) radially shifts the variable eccentric. The stroke length of the crank shaft correspondingly changes. A reproducible setting from zero to the maximum stroke length is possible

New, compact, high performance drive units with worm gear and proven variable eccentric technology for stroke adjustment offering reliable operation in all industrial areas.

Features

- 4 performance ranges LDB, LDC, LDD and LDE each with different reduction ratios
- Simplex drive units with space saving vertical motor
- Multiplex drive units of different performance ratings with horizontally mounted motor
- Double seal of plunger rod to prevent leakage from the drive unit oil to the pump head
- Multiplex drive units with common oilbath and no radial shaft seal rings between the drive elements (less wear parts)

Advantages

- Long service life
- Low maintenance costs, long service intervals
- High mechanical efficiency
- Extremely overload safe
- Minimum adjusting forces for manual and servo stroke adjustment
- Linear, fully reproducible precision stroke adjustment
- Adjustment possible during operation and at rest

Drivers, instrumentation, stroke adjustment

Drivers

- Standard motors with IEC or NEMA mounting dimensions
- With or without hazardous area protection
- Drivers with frequency inverter possible
- Special drivers

Instrumentation

- Monitoring of the pump and integration to a process control

Stroke adjustments

The drive units are available with fixed or adjustable stroke length. Stroke adjustment can be carried out

- Manual
- Electrical
- Pneumatical

Electric stroke actuators

- Integrated limit position and overload protection
- Feedback via potentiometer or 0/4 – 20 mA signal
- Standard enclosure is IP54
- Position controller (optional)
- Hazardous area protection (optional)

Pneumatic stroke actuators

- Integrated hydraulic dampening
- Standards control signal 0,2 – 1 bar
- Optional control and feedback via 0/4 – 20 mA signal



From the pump to the complete system: LEWA ecoflow can be easily integrated in any package



From simplex to multiplex pump: LEWA ecoflow pumps offer unlimited combinations

*Common oil bath:
LEWA ecoflow multiplex pumps
do not require radial shaft seals
between the elements*

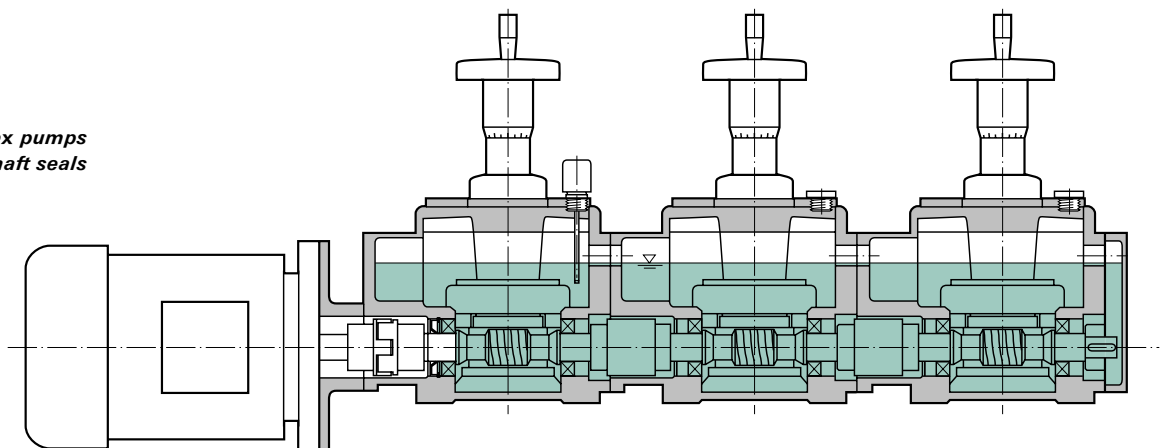

Diaphragm pump heads with hydraulically actuated diaphragm

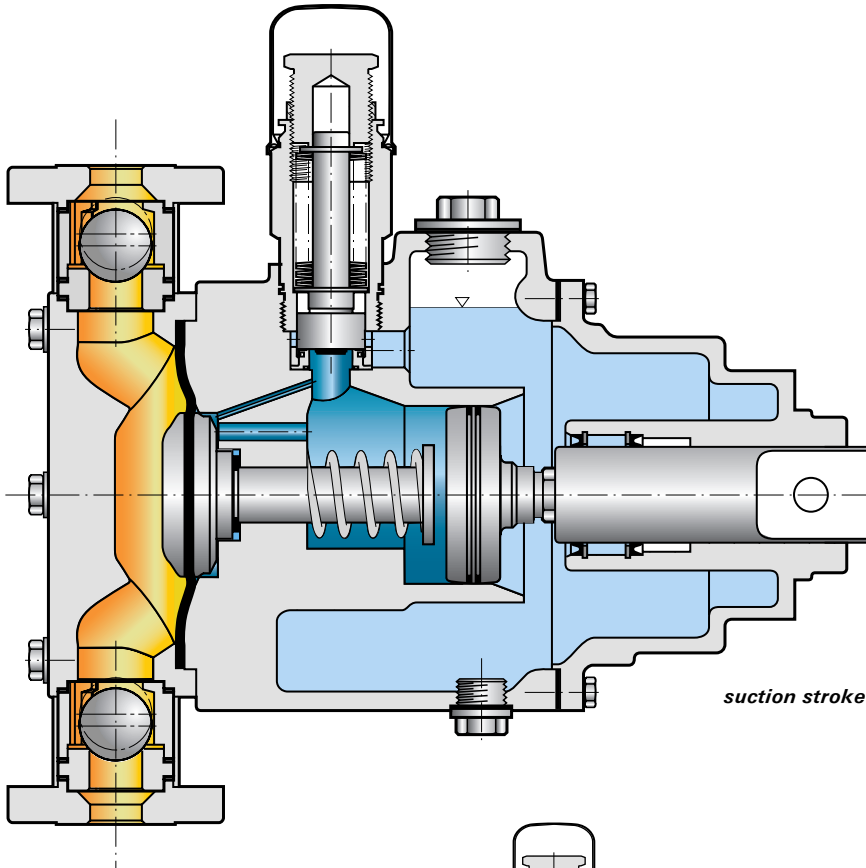

The principle using the M900 series as an example:

The reciprocating plunger displaces hydraulic fluid causing movement of the diaphragm and a like displacement of process fluid. The diaphragm separates hydraulic fluid and the fluid conveyed and seals the operating chamber tightly towards the environment. A pressure limiting valve prevents overload of the pump. The internal leakage at the plunger is balanced by the leakage replenishment valve. Thus the diaphragm always operates in an optimal operating range. This diaphragm control guarantees the very high operational safety of LEWA diaphragm pump heads M900

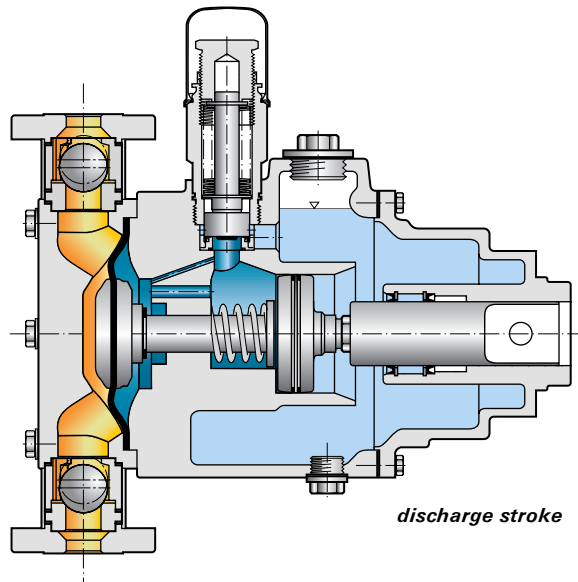

LEWA ecoflow diaphragm pumps are the safe and hermetically tight alternative for medium to high pressures.

LEWA diaphragm pump heads present an economical solution for a variety of metering applications. Today, ecologically damaging, dangerous, sensitive or abrasive fluids are metered with zero leakage diaphragm pumps only.

Damage of one diaphragm, e. g. by wear, is signalled reliably. In spite of this the pump remains leak-tight and operation can continue for a limited period of time.

Advantages of LEWA diaphragm pump heads

- Extremely economical
- Hermetically tight, zero leakage
- Protected against overload by adjustable pressure limiting valve
- Sandwich diaphragm with diaphragm condition monitoring system as standard design
- Durable sandwich diaphragm for minimum maintenance costs
- Absolutely safe dry operation
- High metering accuracy
- Separation of hydraulic fluid and drive element oil
- Gentle conveying of sensitive fluids

The universal and economical diaphragm pump head M 900 with DPS

Performance table

Pressure	up to 400 bar
Flow rate	from 1 l/h – 8 m ³ /h per pump head
Temperature	-20 up to +150°C
Viscosity	up to 100.000 mPa s
Refer to page 12 for technical data	

Extremely sturdy series with PTFE sandwich diaphragm and Diaphragm Protection System (DPS). DPS assures highest safety in operation even in case of faulty handling.

The newly developed diaphragm protection system DPS assures diaphragm position control, such that the diaphragm always moves within an optimal operating range. Independent of external influences, be it extreme operating conditions or gross miss-operation, it is ensured that the diaphragm does not exceed its specified limits. This leads to very long diaphragm service life. DPS, of course, also features the proven diaphragm monitoring system with sandwich diaphragm. This provides additional safe for extremely economical operation.

Advantages of the M 900 series

- Universal application even for critical, ecologically damaging, dangerous, sensitive, highly viscous or abrasive fluids
- Highest safety in operation

- Simple and safe start-up even under extreme conditions
- Safe against faulty operation
- Unsurpassed suction lift comparable with a plunger pump
- Even suitable for pumping from a vacuum
- Very long diaphragm service life
- Simple replacement of diaphragm
- Safe against high suction pressures to 400 bar
- High metering accuracy and wide turndown range

Options

- Duty-matched valve designs
- A variety of connection dimensions
- Heating and cooling jackets
- Pump heads with total heating jacket for melts
- Easy to clean pump heads (CIP)
- Hygienic design for food, pharmaceutical and biotechnological applications
- Special materials, e. g. Hastelloy
- Diagnostic capability for online- and offline monitoring

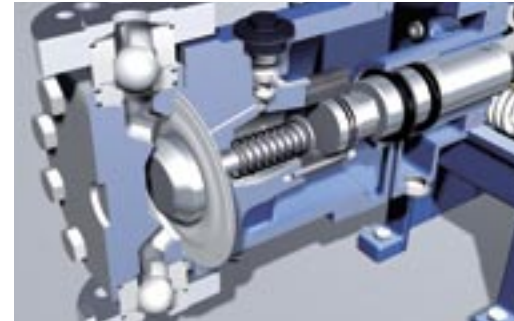

Safe by DPS:
The new diaphragm control ensures that the diaphragm is always in the correct operating position



Performance table

Pressure	up to 1200 bar
Flow rate	from 1 l/h – 2 m ³ /h per pump head
Temperature	up to +230°C
Viscosity	up to 500 mPa s

Refer to page 12 for technical data

For high pressures M 200 diaphragm pump heads

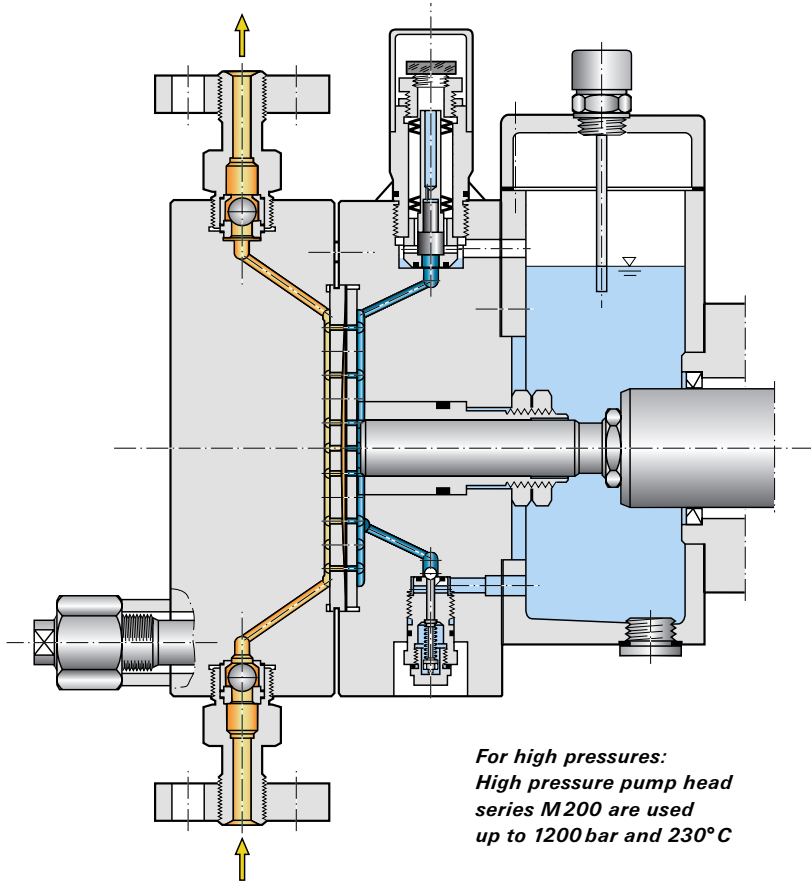

*For high pressures:
High pressure pump head
series M200 are used
up to 1200 bar and 230°C*

High performance pump head series with metal diaphragm for high pressures and high temperatures

Diaphragm pumps with metal diaphragms are used when high pressures or temperatures must be handled or for high diffusion resistance e.g. nuclear technology. For maximum security and long diaphragm life, the deflection of the diaphragm is positively limited in both directions, so that faulty operation cannot cause diaphragm overload. Additional safety is provided by the sandwich diaphragm with diaphragm monitoring system at pressures up to 1200 bar.

Advantages of the M 200 series

- Extremely high safety standard
- Protected against diaphragm overload and faulty operation
- Suction pressure proof at rest, in operation up to 100 bar
- Diffusion tight diaphragm
- Durable diaphragms by uniform deflection via contour plate and protection against excessive diaphragm deflection



*Long service life:
The metal diaphragms
are uniformly displaced
and are protected from
over-stressing*

The economical K100 – 500 plunger pump heads

Performance table

Pressure	up to 500 bar
Flow rate	from 0,1 l/h – 10 m ³ /h per pump head
Temperature	up to +400°C
Viscosity	up to 100.000 mPa s
Refer to page 12 for technical data	

Plunger pump heads are a good choice for simple applications with non-critical, harmless fluids.

For critical, abrasive, toxic or flammable fluids diaphragm pump heads are recommended.

Advantages of plunger pumps

- Economical solution for simple metering applications
- Standard plunger of oxide ceramics offer optimum conditions concerning wear and chemical resistance

Options

For special problem solutions a number of options and special solutions are available:

- Heating or cooling jacket
- Fully heated pump head with accessible valves for melts
- Flushing connection
- Duty matched plunger seals for the most different fluids

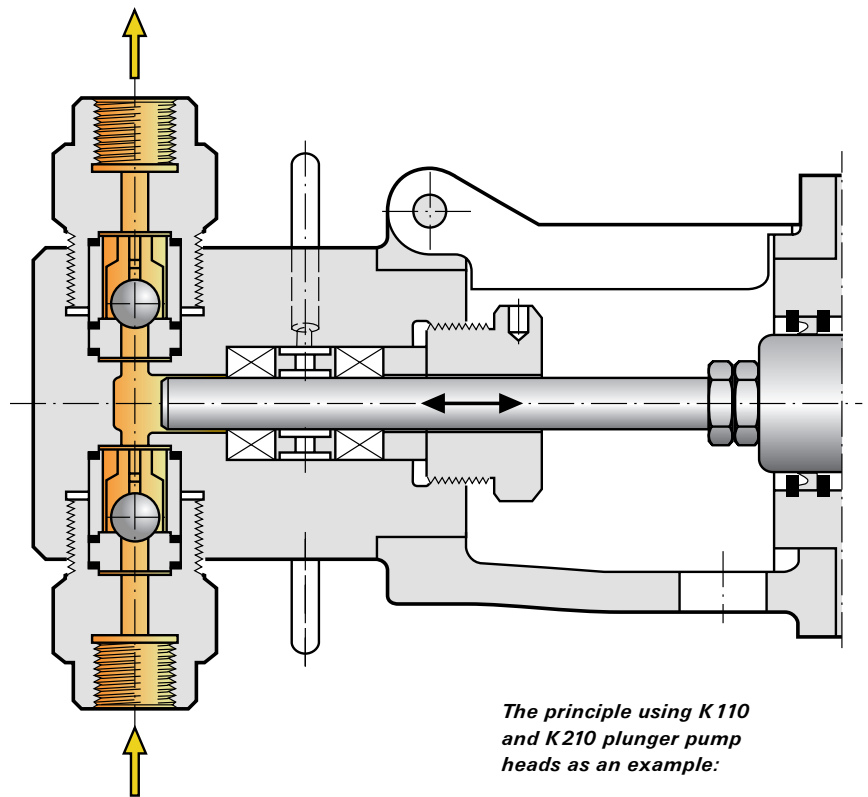

The principle using K 110 and K 210 plunger pump heads as an example:

The reciprocating plunger directly displaces the process fluid. As the plunger and plunger seal are wetted, the best performance for the application is achieved by optimal selection of plunger material and seal design

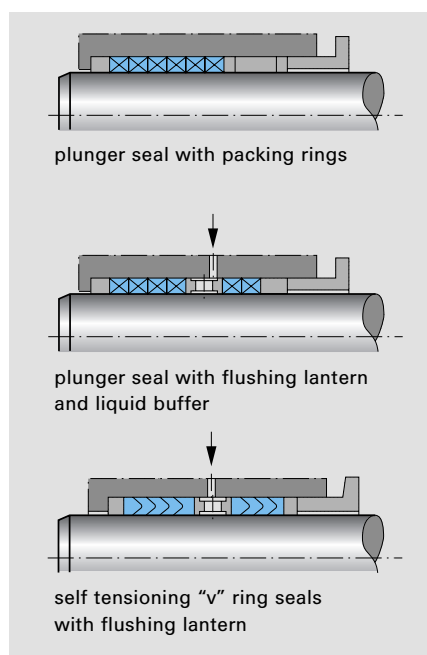

The plunger seal selection is dependent on the fluid, pressure and temperature

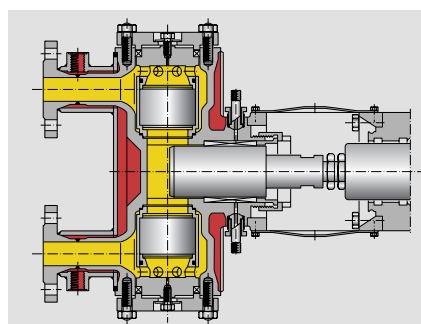

One of many possible options: e.g. pump head K 500 with total heating jacket and accessible valves



For non-critical fluids: plunger pump heads are mainly used for simple, non-critical fluids

Reliable pump valves

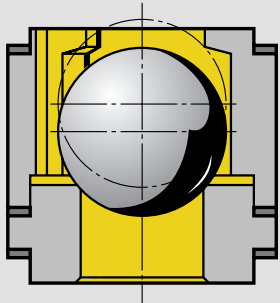

ball valve

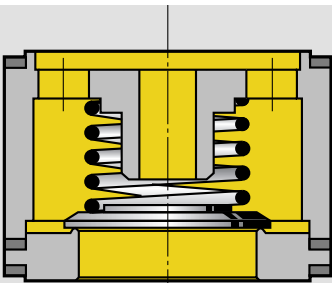
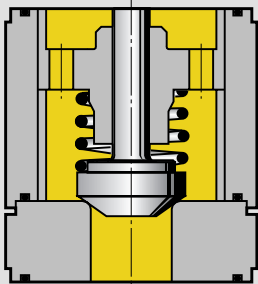

plate valve



cone valve

Valves for any requirement

In addition to the pump head type, the proper valve design is of major importance in the suitability of the pump for the service. LEWA's ecoflow program offers a wide range of valve designs for the most different applications. Count on our decades of experience to assure a correct valve selection. Depending on valve size and the corresponding requirements ball-, plate- or cone valves of different materials are used.

Ball valves

Standard valves for nominal sizes up to 15 mm. Optimal flow characteristics and reliable function even with contaminated fluids.

Plate valves

Standard valves for nominal sizes 25 mm and up and pressures to 200 bar. Suitable for high stroking frequencies due to the low mass of the plate.

Cone valves

Standard valves for nominal sizes 25 mm and up and for high pressures.

Options

- Valve parts with low wear
- Hardened valve parts or designs of hard metal, oxide ceramics or silicon nitride
- Double ball valves for even more safety for small sizes
- Slurry valves of different designs, e.g. with seat and sealing element of hard metal



Correct installation and accessories assure proper function

The trouble-free function of a metering pump depends mainly on correct installation for the application and process fluid characteristics. Properly selected and sized accessories turn the pump into a functional system. Your success is our success – please consider our advice. We can also offer duty-matched accessories or a complete, proven skid system with suction and discharge pipe line.

Dirt traps

Many fluids contain contaminants which can disrupt the function of the pump valves ranging from minor flow fluctuations to complete failure of the metering process. This can be avoided with the installation of a strainer in the suction line.

Pulsation dampeners

Metering pumps have a pulsating flow. During each stroke, the column of fluid in the suction and the discharge lines must be accelerated and then decelerated again. LEWA has the know-how and the accessories for an optimum match of pump and system. Pulsation dampening can be required for two reasons:

- To reduce high, non-permissible pressure fluctuations
- To create a nearly continuous flow

The simplest and most economical way to meet either requirement is the use of pulsation dampeners. The use of a multiplex pump will achieve a similar result.

Safety and pressure retaining valves

Safety valves

They prevent pressure overload of pump and system. Metering pumps are positive displacement devices and always must be protected against dead-heading if there is any possibility of blockage of the discharge line during operation such as sedimentation buildup in the pipeline, accidental closure of a shutoff valve, etc..

Hydraulically actuated diaphragm pumps are protected by a pressure limiting valve integral to their hydraulic circuit.

Back pressure valves

They prevent uncontrolled flow through the pump (over-metering) when – due to static or dynamic reasons – the pressure at the suction flange is higher than at the discharge flange. Usually the retaining pressures required are low.

Condition monitoring

Condition monitoring systems allow the monitoring of the pump and the recording and evaluation of suitable physical values. Mobile offline as well as local online systems with continuous data recording and evaluation are possible.

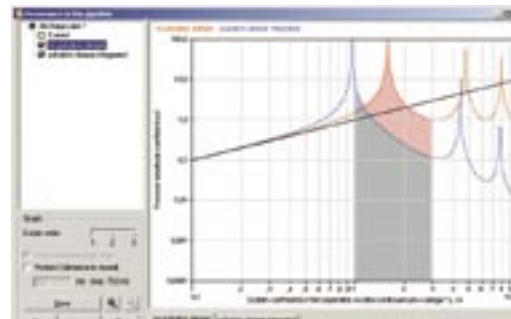

Computer supported pipe line design



Pulsation dampeners



Safety valve

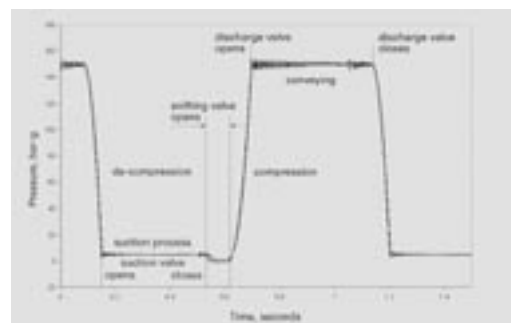

Pressure-time progress for condition monitoring systems

Technical data LEWA ecoflow

Performance range table

for determining the drive element size. The graphs for the LEWA ecoflow series apply to a simplex pump. The flow rate stated is per pump head.

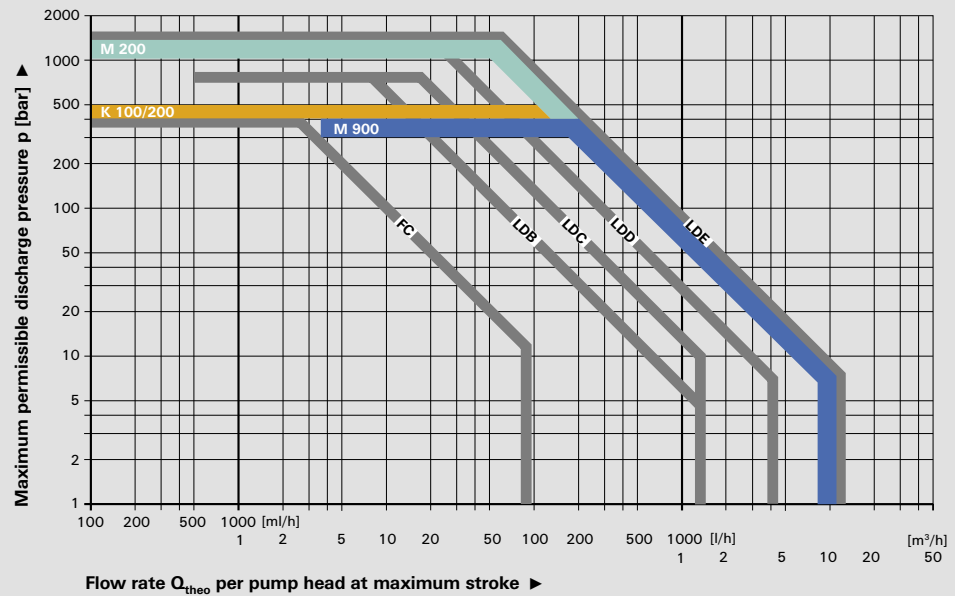

General overall dimensions

Typ	L [mm]	B [mm]	ΔB [mm]	H [mm]
LDB	400	400	185	260
LDC	450	500	220	320
LDD	700	750	280	610
LDE	800	900	350	690

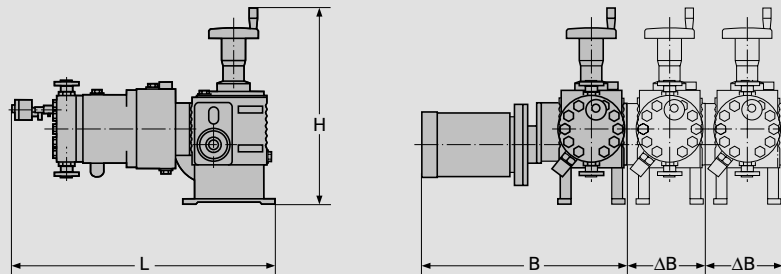

The dimensions given may differ depending on the size and type of pump head mounted

Inquiry data for selecting a pump

For selecting your specific pump we need the information on the right from you.

Please fax to:

LEWA Herbert Ott GmbH + Co

Fax-Nr. +49 (71 52) 14-13 03

Your inquiry will be answered immediately.

Metered fluid

Flow rate required	[l/h]
Operating pressure at discharge flange	[bar] abs
Operating pressure at suction flange	[bar] abs
Operating temperature (OT) max./min.	[°C]
Density at OT	[g/cm³]
Viscosity at OT	[mPa·s = cP]
Solids content / density / description	[%/g/cm³]
Solids particle size / solids hardness	[mm/Mohs]

Motor data

Hazardous area protection
Enclosure
Voltage
Current type
Rated frequency

The LEWA micro-flow metering pumps

The micro-flow metering pumps with hydraulically actuated metal diaphragm were developed for micro metering. For decades they have proven to be safe, reliable and accurate metering pumps in laboratories, pilot plants, process research and for the odourizing of gas flows – e.g. natural gas odourization.

- Hermetically tight, leak-free
- Diffusion-tight metal diaphragm of stainless steel or Hastelloy resistant against almost all fluids handled in a laboratory. Long service life and pressure stiff even at high pressures
- Zero play drive units with precise stroke length adjustment
- Wide range of accessories
- Controls for the configuration of metering systems for closed loop control of the metered flow

M and MAH series

Metering devices and pumps in three performance ranges. Pump with solenoid drive and control in a uniform cabinet (M series) or with separate control (MAH series).

- Flow adjustment via stroke length with a finely scaled handwheel and via stroke frequency, external control 0/4 – 20 mA and triggering of single strokes is possible
- Pump heads of stainless steel or Hastelloy, valve seats of hard ceramics and valve balls of ruby
- Connections for heating- and cooling fluid, sterilizable up to 150°C
- Ex-protection EExe IIT4 (MAH)
- Metered flow 0 – 250 ml/h up to 0 – 1800 ml/h
- Max. operating pressure 50 bar

MBH, PBH and PKH series

These series are hydraulically actuated metering pumps. The MBH has an electro-magnetic drive; the PBH and PKH are equipped with a pneumatic drive.

- Adjustment of the metered flow via stroke length and via stroke frequency, external control 0/4 – 20 mA and triggering of single strokes is possible (MBH)

- Ex-protection EExem IIT4 IP54 (MAH)
- Heating- and cooling (option PKH)
- Performance:
 - MBH: 0 – 4.2 l/h at 15 bar and 0 – 2.2 l/h at 40 bar
 - PBH: 7.7 l/h at max. 62 bar
 - PKH: max. 10 l/h, max. 300 bar

MLM series

These metering pump in two frame sizes and 15 performance ranges with powerful solenoid drive are also suitable for high-pressure applications.

- Flow adjustment via stroke length and via stroke frequency
- Wide range of pump head materials, valves and valve connections
- Metered flow 0 – 0.570 l/h up to 0 – 57.5 l/h
- Max. operating pressure 560 bar
- Ex-protection EExe IIT4 resp. T5

FCMk series

Metering pumps in two performance ranges with electric motor drive. Sturdy, linear adjustable, zero-play cam and spring drive for applications up to the high-pressure range.

- Metered flow adjustment via a finely scaled handwheel
- Stroke adjustment with electric or pneumatic stroke actuators (option)
- Multiplex pump design is possible
- Pump heads of stainless steel or Hastelloy, valve seats of hard ceramics and valve balls of ruby
- Internal pressure limiting valve
- Sterilizable up to 150°C, connections for heating- and cooling fluid (option)
- Metered flow 0 – 0.110 l/h up to 0 – 1.885 l/h
- Max. operating pressure 400 bar

Performance range

Pressure	up to 560 bar
Flow rate	from 0,1 l/h – 60 l/h per pump head
Temperature	up to 200°C
Viscosity	up to 500 mPa s



FCMk with electric stroke adjustment



M series



MLM



PBH

Wide scope of supply



LEWA ecodos



LEWA triplex process diaphragm pumps



LEWA metering systems and packages

In addition to our ecoflow series, LEWA offers other metering pumps, process diaphragm pumps, metering systems and metering packages. If you are interested in our complete scope of supply, we would be pleased to send you detailed information and our comprehensive catalog.

■ LEWA ecodos

Standard diaphragm metering pumps for low pressure services using a patented, mechanically actuated four-layer PTFE sandwich diaphragm for multiple safety. In simplex or multiplex configurations.

Performance range

Flow rate	up to 1,5 m ³ /h per pump head
Discharge pressure	up to 20 bar

■ LEWA process diaphragm pumps

Eliminate fugitive emissions with leak-free LEWA process diaphragm pumps for high pressure, high flow services. No process fluid can escape to the atmosphere. LEWA triplex with compact monoblock drive element and LEWA ecoflow in variable multiplex assembly guarantee zero leakage and low maintenance operation.

Performance range

Flow rate	up to 180 m ³ /h
Discharge pressure	up to 1200 bar

■ LEWA metering systems

LEWA metering systems are modular combinations of pump with adjusting device for stroke length and/or speed. Flow meters (volume- or mass-flow) and closed loop controller. The metering pump is operated in a closed control loop.

■ Standard metering packages

LEWA has developed standardized solutions for a wide range of applications. Examples for this are acid dilution, gas odourization, polyethylene cross-linking, and solar powered chemical injection.

■ Tailor-made metering packages

LEWA metering/mixing packages support process automation and are designed and built to meet specific customer requirements with a complete solution for the corresponding application. LEWA supplies complete, ready to operate problem solutions for the corresponding application. The scope of supply covers turn-key standard metering packages up to the engineering and commissioning of complex systems with customized process controls, displays, data recording and external interfaces to the plant's central control system.

Take advantage of our expertise

LEWA is a global supplier of metering pumps, process pumps, and metering systems. We strive for a close partnership with our customers in all activities related to our products. Your complete satisfaction begins with consultation before or after an order is even placed, service and repair, spare parts supply, maintenance and training.

Our services extend from comprehensive documentation for our products through fast spare parts supply, expert repairs and rebuilds, and field service for maintenance and training. This increases the up-time of LEWA pumps and packages and assures trouble-free operation.

We would be pleased to present detailed information on our scope of supply, our services and our resources that can be made available to you. Our over 50 years of experience in fluid metering and controlled volume applications is behind the design support we offer.

For this we offer:

- Correct pipe line calculation
- Fluid evaluation from the expert
- Worldwide, competent service
- Maintenance directly from the manufacturer
- Seminars from the specialist
- Spare parts supply with 24/28 hours service
- Installation of diagnosis systems



Profit from LEWA's know-how at an early stage, during design or ongoing operation



On-site without delay: Consulting, maintenance or service. Being close to our customers is very important to us

*Worldwide:
With eight LEWA Centers of Competence around the globe, and over 50 experienced representatives, we never are far away*



LEWA always close to you

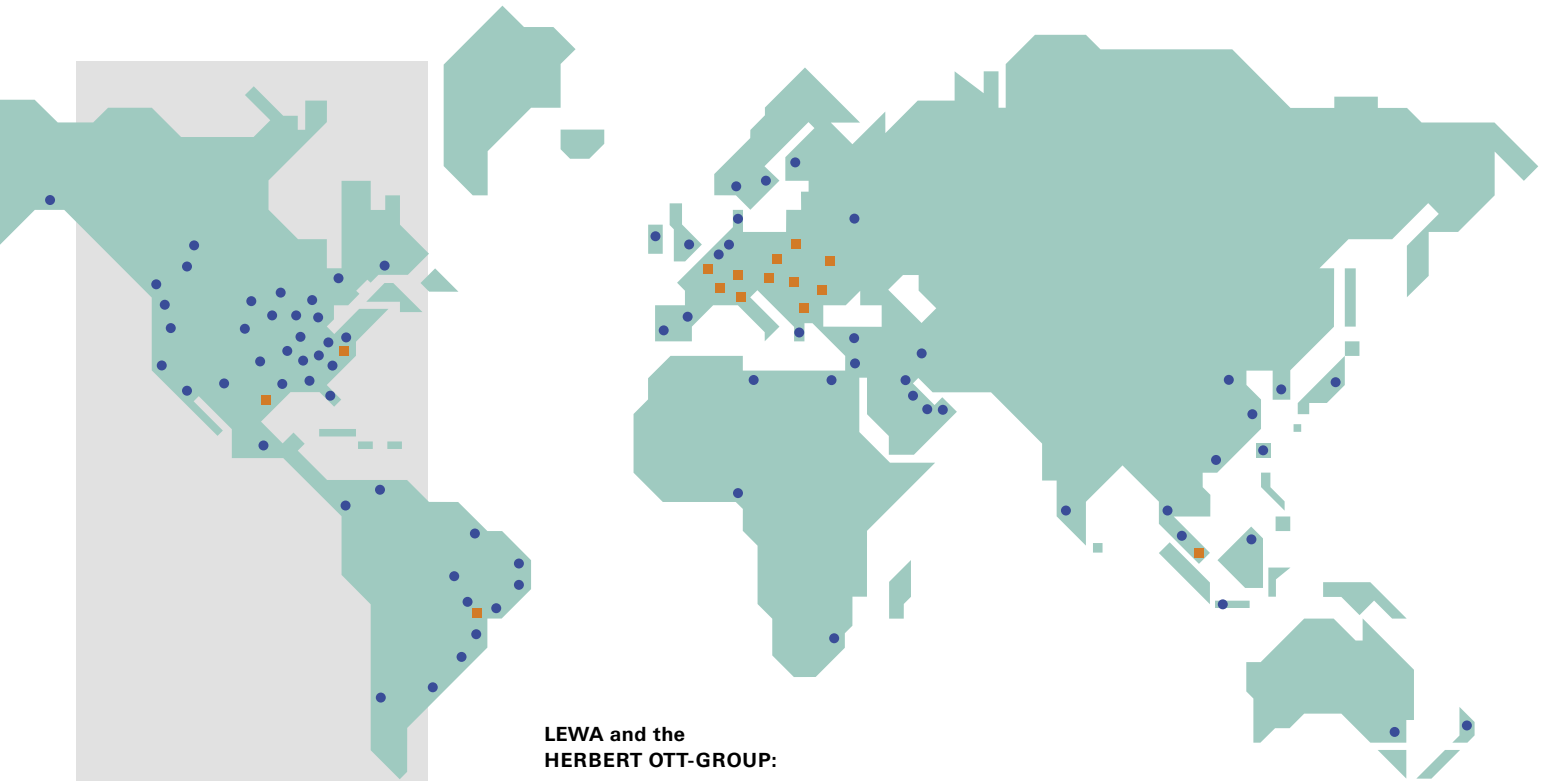

LEWA and the HERBERT OTT-GROUP:

The HERBERT OTT-GROUP consists of the OTT HOLDING INTERNATIONAL GMBH, the LEWA producing company in Leonberg and eight affiliated sales companies in the USA, Singapore, Brazil, Switzerland, Germany, Austria, France and Italy.

Parallel and of equal status these sales companies market equipment complementary to LEWA products from other, leading manufacturers, stock complete machines and spare parts. Also they offer competent consultation and qualified service locally.

USA / North and Central America

AMERICAN LEWA, INC.
Phone +1/508/429-7403
Fax +1/508/429-8615
sales@amlewa.com
www.americanlewa.com

Singapore

LEWA ASIA HERBERT OTT PTE LTD
Phone +65/68 61 71 27
Fax +65/68 61 65 06
info@lewa-asia.com.sg

Brazil

LEWA SULAMERICANA Ltda.
Phone +55/11/56 77 04 66
Fax +55/11/55 64 68 27
info@lewa-sulamericana.com.br

Switzerland

Herbert Ott AG
Phone +41/61/7 17 94 00
Fax +41/61/7 17 94 01
info@herbert-ott-ag.ch
www.herbert-ott-ag.ch

Germany

HOV Herbert Ott Vertriebs-GmbH + Co
Phone +49/71 52/60 91-0
Fax +49/71 52/60 91-59
hov@hov.de
www.hov.de

Austria

LEWA Herbert Ott KG
Phone +43/1/8 77 30 40-0
Fax +43/1/8 77 30 40-29
info@lewa.at
www.lewa.at

France

POMPES LEWA S.A.R.L.
Phone +33/1/30 86 74 80
Fax +33/1/39 57 06 08
info@pompes-lewa.fr
www.pompes-lewa.fr

Italy

POMPE LEWA S.R.L.
Phone +39/02/93 58 26 60/1
Fax +39/02/93 58 26 57
info@pompe-lewa.it
www.pompe-lewa.it



LEWA®

LEWA Herbert Ott GmbH + Co

Ulmer Strasse 10
D-71229 Leonberg

Telephone +49 (71 52) 14-0
Telefax +49 (71 52) 14-13 03
E-mail lewa@lewa.de
Internet www.lewa.de