

Membrane Pumps
Solids Handling Pumps
High Pressure Pumps
Marine Pumps

ABEL HMT & HMQ

Hydraulic Membrane Pumps

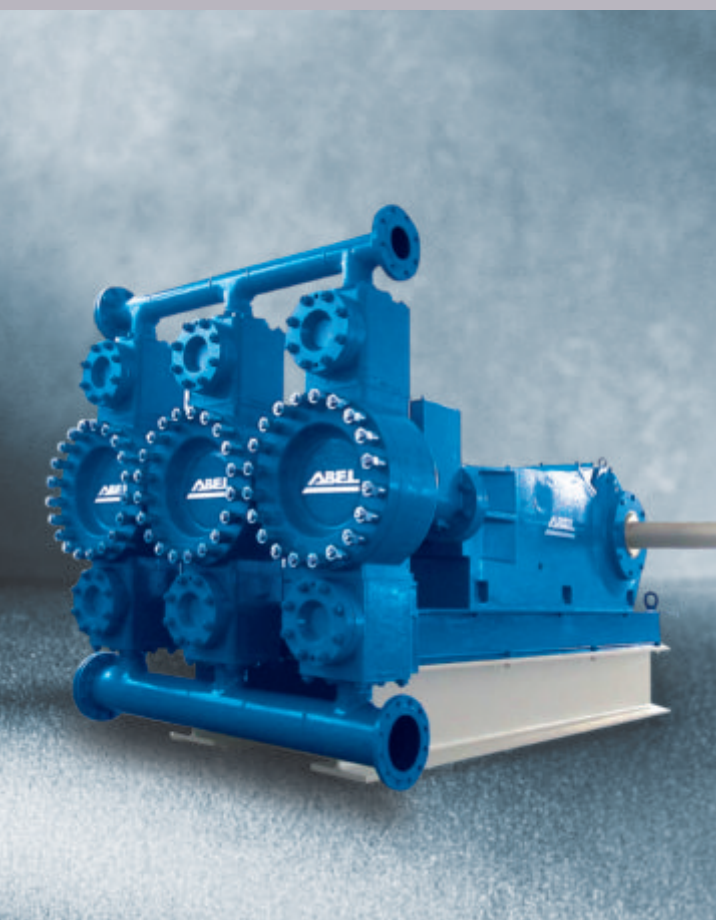

Versatile. Efficient. Reliable.

ABEL®
Pump Technology

ABEL HM

Highly efficient, extremely adaptable

ABEL hydraulic membrane pumps were developed to meet the demand for pumps that are very efficient, very dependable and long-lasting.

The ABEL Series HM is characterised by high volumetric efficiency and extreme adaptability. These pumps can be adjusted to best meet customer needs depending on predefined operating pressure and flow rate. They are available in four basic designs that take advantage of modern membrane technology.

The entire ABEL Series HM complies with the quality management requirements of DIN EN ISO 9001:2000. Of course this also includes factory acceptance testing for each pump.

The following HM Series are available for different flow rates and pressures:

- HMS = Single action (simplex)**
- HMD = Double action (duplex)**
- HMT = Triple action (triplex)**
- HMQ = Quadruple action (quadruplex)**

Materials of parts that touch the product:

- ▲ Nodular cast iron
- ▲ Rubber lined nodular cast iron
- ▲ Cast stainless steel (also available in duplex stainless steel)
- ▲ Polypropylene



Series HM pumps are also available with ATEX certification.

ABEL HMD



ABEL HMT



ABEL HMQ



Applications

- As a process pump for sludge transfer
- Feeding filter presses
- Feeding spray driers
- Feeding incinerators or reactors
- Dosing

Application areas

- Mining
- Power plants
- Ceramics industry
- Chemicals and petrochemicals industry
- Sewage treatment
- Cement industry
- Galvanisation industry
- Automobile industry

ABEL hydraulic membrane pumps take full advantage of modern membrane technology. They are equipped with pre-formed membranes and pressure-balanced membrane positioning that stabilises pressure and flow for the membrane movement between the front and rear limit of stroke. Unlike most other membrane pumps, ABEL Series HM membranes are not stretched during the stroke. This ensures longer membrane service life and more dependable operation.

Operation

The piston and membrane move from the centre position to rear dead centre during the suction stroke. The membrane contacts the backside on the membrane housing before the piston has completed its suction stroke. The piston continues to move towards the rear dead centre, creating negative pressure on the hydraulic side. Fluid travels from the hydraulic reservoir tank through the return valve and the replenishing port into the cylinder area until the negative pressure is equalised.

The piston performs the discharge stroke and moves from the rear dead centre to the front dead centre. The membrane performs a discharge stroke on its end and forces the pumping medium out of the pump housing. If the membrane moves beyond its front limit of stroke, the membrane rod that is connected to the membrane opens a port that leads to the hydraulic reservoir tank. The excess fluid travels through the port back into the hydraulic reservoir tank so that the membrane does not move beyond its limit defined for the discharge stroke.

A full-stroke safety release valve on the hydraulic side of each of pump chambers prevents the allowable pump pressure from being exceeded.

Depending on pump pressure and pumping medium, ABEL Series HM pumps can be equipped with ball valves or cone valves. Ball valves are the best choice for low pressure applications and/or fibrous media.

For high pressure applications and/or mineral slurries spring-loaded cone valves with an elastomer insert are used.

ABEL reverse valves are a special feature. They are used for watery solutions where larger particles could quickly drop out. To keep a particle suspended in a liquid, the particle needs to be propelled at a velocity that is greater than its sedimentation velocity (critical velocity). This is not always possible on the product side of a pump as the cross-sectional area is often several times larger than the cross section of the pipe. As a result, larger particles may settle in the pump housing or the suction-side valves, which can lead to a loss of function. This can be prevented by using spring-loaded cone valves in a reverse design, that is, by reversing the pumping direction within the pump. This balances the effec-

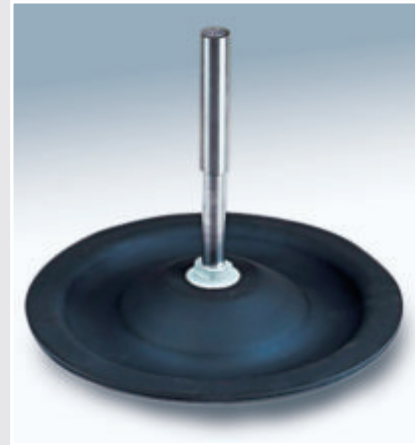

tive direction of the flow and gravity vectors, avoiding the risk of sedimentation inside the pump.

Functional principles

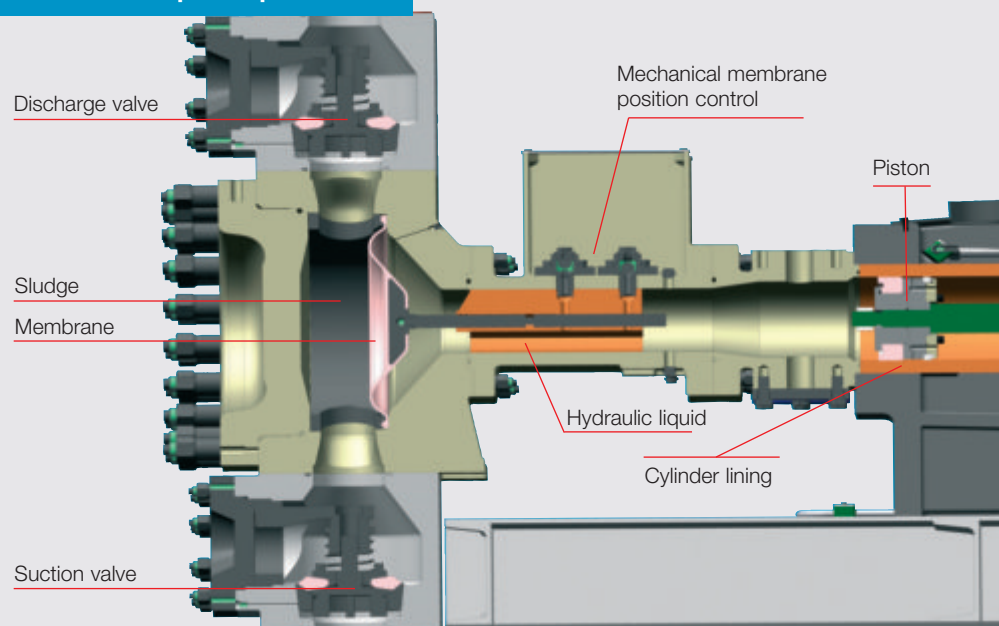

ABEL HMT

Hydraulic Triplex Membrane Pump

The ABEL HMT is a single-acting, slow-running, dry-run secure triplex piston membrane pump and can be used for a performance range up to 25 MPa and pump flows up to 600 m³/h.

For hydraulic solids transfer, the ABEL HMT provides a clever solution to pumping suspensions that have high dry substance content and a high specific weight. The strong points of the HMT are its quiet operation (low residual pulsation) and its ability to function at pressures above 10 MPa.

The triplex gearbox can run at high speeds because it has a crankshaft that is especially designed for this duty. The crankshaft has a crank offset of 120° which gives it a steadier volumetric flow than quadruple-action pumps. An external reduction gearbox drives the crankshaft, which is resistant to bending and is guided by two self-aligning roller bearings. The pistons are pressurised on one side.

A triplex piston pump with wear-resistant cylinder linings is available by special request.

The ABEL HMT makes it easy to assemble and disassemble cylinder linings and pistons. By loosening a clamp coupling and separating the divided piston rod, you can open the cylinder lining fastener and remove the cylinder lining, pistons and the front half of the piston rod from the lantern without disassembling the product sides of the pump.

Pump flow can be regulated using a frequency converter. If required, the gearbox of this series is with an external forced oil lubrication system as standard.

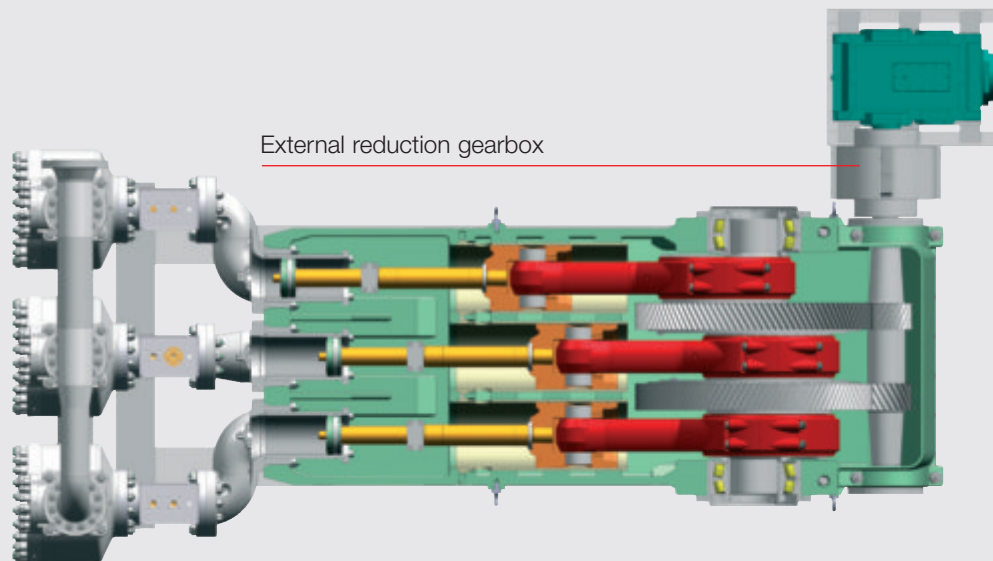

The flow rate can be regulated automatically using a pressure sensor or other 4-to-20 mA signals. A precision-tuned pulsation dampener (suction side and discharge side) is included in the scope of supply.



ABEL HMT

Applications and application areas

ABEL HMT pumps can be used to transfer a variety of different types of high-viscosity ash and mine slurry. They offer the chemicals industry an attractive alternative to conventional plunger pumps and piston pumps, particularly for low flow applications.

ABEL pumps have been used around the world for over 50 years to drain mines and transfer mine slurry.

A large number of ABEL pumps are currently in operation in the mining industry, power plants and the metal-processing industry.

The Konkola copper mine in Chingola (Zambia) processes copper slurry with thickeners and cyclones and, with the help of ABEL HMT pumps, transfers it 3.5 km to the inside of the mine for backfilling.

Two ABEL HMT-F-160-1000 pumps are used to transfer the slurry. Up to 60% of the slurry is solid matter. The flow rate of the pumps is 90 m³/h, and a pressure of 5 MPa is needed to cover the distance of 3.5 km.

Operating costs have remained very low since the first pump was commissioned. Thanks to the HMT's high efficiency, energy consumption for 90 m³/h and 50 bar has been less than 160 kW.

Spare parts for the HMT are only required when replacing the cone valves every 5,000 to 7,000 hours.

The membranes are replaced every 12,000 to 16,000 hours as a precautionary measure.

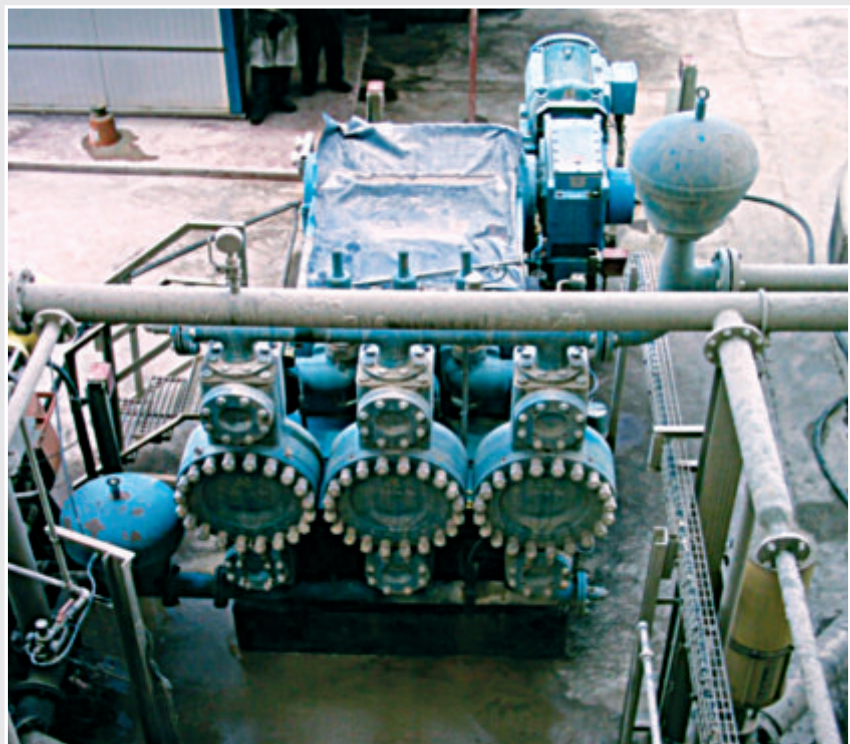

This positive track record led the customer to purchase a second pump of the same type in 2007.

ABEL HMQ Hydraulic Quadruplex Membrane Pump

The ABEL HMQ is a quadruple-acting piston membrane pump that is primarily used for high flow applications up to 500 m³/h and a pump pressure of up to 10 MPa.

The two pistons on a quadruple-acting pump are offset relative to one another by a crank angle of 90°. The result is that a different piston surface generates pump flow after each 90° crank angle. Since the front side of the piston is larger than the rear side of the piston (the piston rod diameter reduces its surface area), different volumes develop on the two sides of the piston; this imbalance would reveal itself as high residual pulsation if an appropriately-sized pulsation dampener were not used.

The Series HMQ is equipped with an eccentric shaft and an integrated, double-helical reduction gear section. An external forced oil lubrication system is used for lubrication. This gives the gearbox a very compact, robust design.

These gearboxes have been part of the ABEL line-up for over 30 years. This trusted technology, combined with the modern technology of the

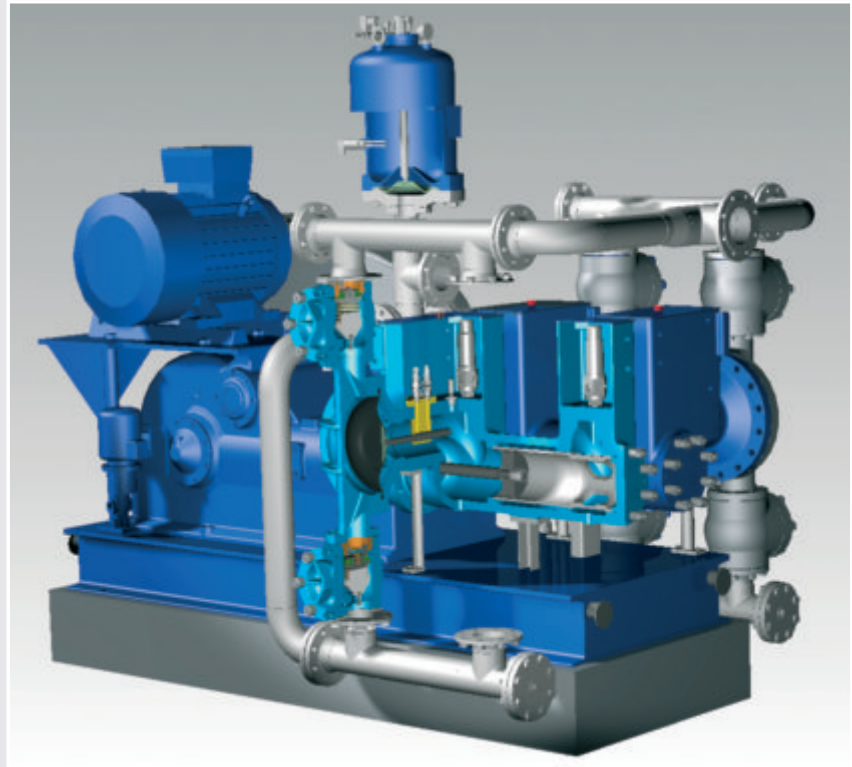

Series HM, produced the Series HMQ, which represents a competitive alternative to conventional piston pumps and piston membrane pumps, particularly for the pressure range below 10 MPa.

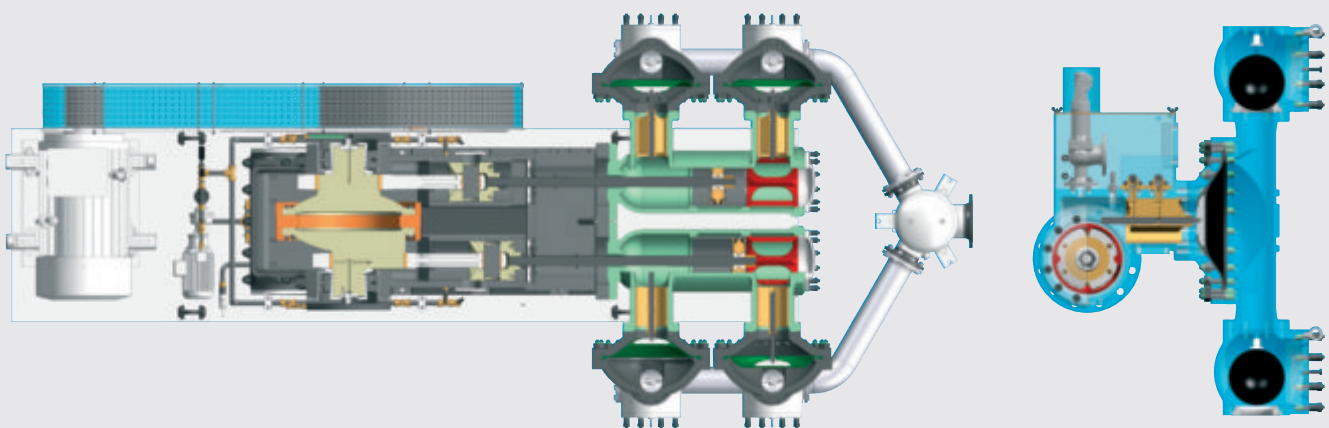

ABEL HMQ

Applications and application areas

Series HMQ piston membrane pumps are being used successfully around the world for applications as diverse as transferring phosphate slurry, feeding filter presses in the cement industry, backfilling in salt mines, as well as pumping ore slurry, fly ash and bottom ash.

Low pressure Series HMQ pumps are a particularly attractive alternative to using single-stage or multi-stage centrifugal pumps to pump mine slurry and fly ash.

The higher purchase price of a piston membrane pump is offset by lower energy costs that come from greater efficiency and by a reduced need for maintenance.

Since piston membrane pumps easily handle mixtures with high solids concentrations, the amount of water in the medium can also be reduced significantly in some cases. The performance curve of Series HMQ pumps is stable with regard to the pressure, which makes it easier to accurately calculate hard-to-find pressure losses.





Membrane Pumps
Solids Handling Pumps
High Pressure Pumps
Marine Pumps

ABEL[®]
Pump Technology

ABEL GmbH & Co. KG
Abel-Twiete 1
D-21514 Buechen, Germany
Phone +49 4155 818 - 0
Fax +49 4155 818 - 499
mail@abel.de · www.abel.de